

**WCN2-0056B7-C41
SPECIFICATION**

WCN			CUSTOMER Confirmed
Prepared by	Checked by	Approved by	
Fei 2017-8-26	Athena	William	
REVISION RECORD			



REVISION: A0

■ **Outer Dimension:**

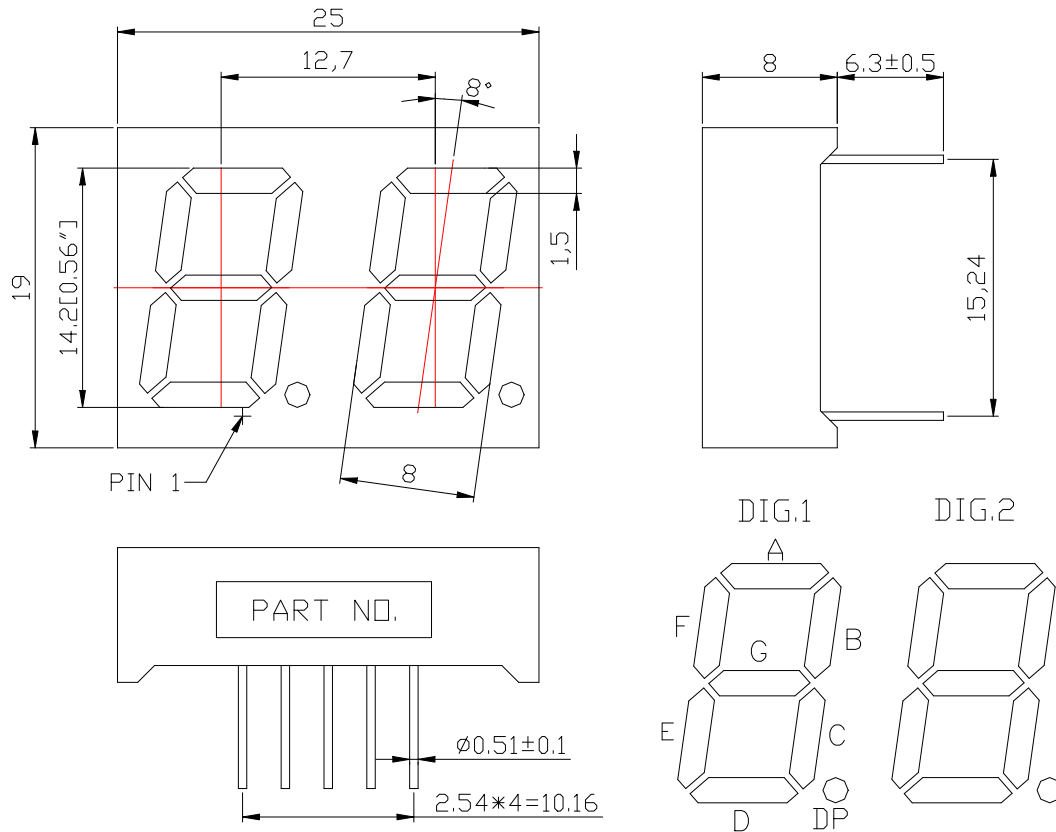

Notes: Unless otherwise stated, The tolerance is $\pm 0.25\text{mm}$.

■ **Circuit Diagram:**

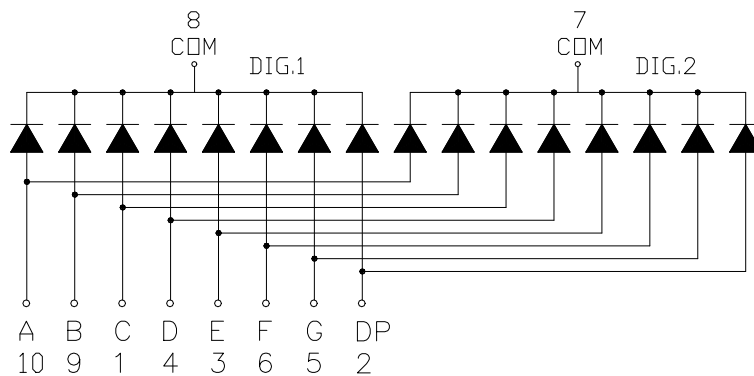

■ **Pin Connection:**

PIN NO.	CONNECTION	PIN NO.	CONNECTION
1	Anode C	6	Anode F
2	Anode DP	7	Common Cathode Dig 2
3	Anode E	8	Common Cathode Dig 1
4	Anode D	9	Anode B
5	Anode G	10	Anode A



WCN Opto Group Co., Limited

■ Features:

- High Reliability
- Color: Blue
- Low Power Requirement
- Easy Assembly

■ Description:

- Dual Digit Display
- Digit Height: 14.2 mm (0.56")
- Black Face and Milky Segment

■ Absolute Maximum Rating (Ta=25°C):

Parameter	Symbol	Condition	Color	Rating	Units
Power Dissipation Per Segment	P _d	—	Blue	90	mW
Forward Current Per Segment	I _F	—	Blue	25	mA
Peak Forward Current Per Segment	I _{FP}	1/10 Duty 10KHz	Blue	100	mA
Reverse Voltage Per Segment	V _R	—	Blue	5	V
Operating Temperature Range	T _{opr}	—	—	-35~+85	°C
Storage Temperature Range	T _{stg}	—	—	-35~+85	°C

■ Electrical/Optical Characteristics Rating(Ta=25°C)

Item	Symbol	Test conditions	Location	Rating			Units
				Min.	Typ.	Max.	
Forward Voltage	V _F	I _F =20mA	Per Segment	2.6	3.2	3.60	V
Reverse Current	I _R	V _R =5V	Per Segment	—	—	10	μA
Luminous Intensity	I _V	I _F =5mA	Per Segment	10501	16500	26000	μcd
Peak Emission Wave Length	λ _P	I _F =5mA	Per Segment	—	—	—	nm
	λ _D				470		
Spectral Line Half Width	Δλ	I _F =5mA	Per Segment	—	20	—	nm
Luminous Intensity Matching Ratio (Segment to Segment)	I _{v-m}	I _F =5mA	—	—	—	1.2:1	

■ Luminous Intensity Sorting: (Luminous Intensity Tolerance is +/-10%)

Rank	Symbol	Condition	Min	Max	Unit
Q	Q	I _F =5mA	10501	12800	μcd
R	R	I _F =5mA	12801	15250	μcd
S	S	I _F =5mA	15251	18000	μcd
T	T	I _F =5mA	18001	21500	μcd
U	U	I _F =5mA	21501	26000	μcd

■ Soldering Conditions: Soldering Temp. ≤+260°C, Soldering Time. ≤3sec.
(at 2mm Distance from The Case of Reflector Edge)

■ Typical Elector-Optical Characteristics Curve:

Fig1. Forward Current vs. Forward Voltage:

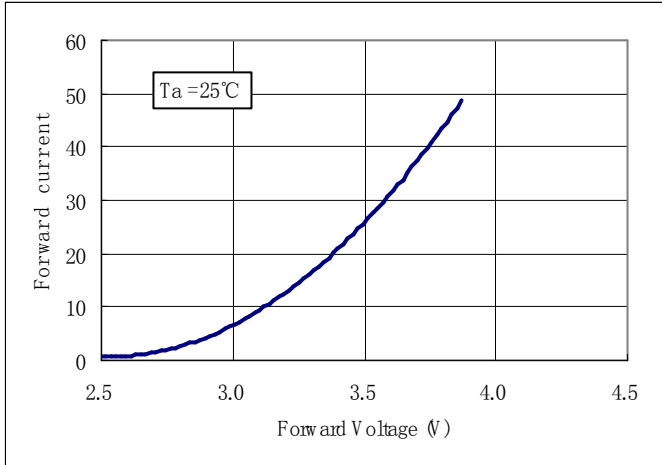

Fig2. Forward Current vs. Relative Intensity:

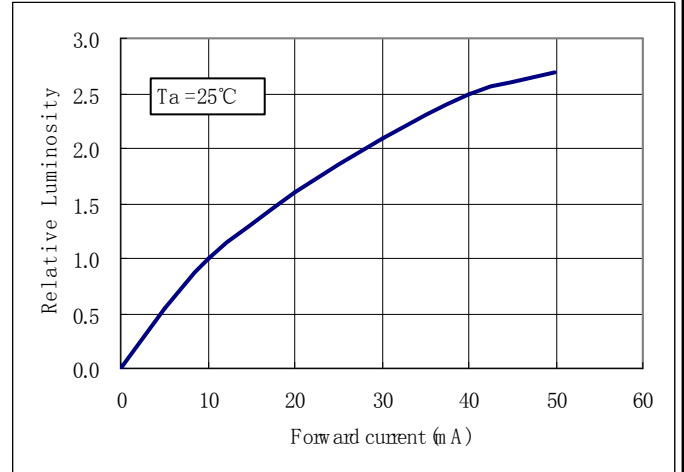

Fig3. Forward Current vs. Relative wavelength:

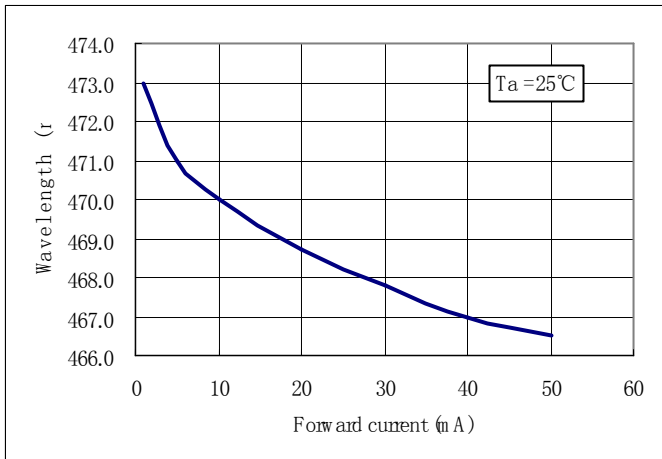
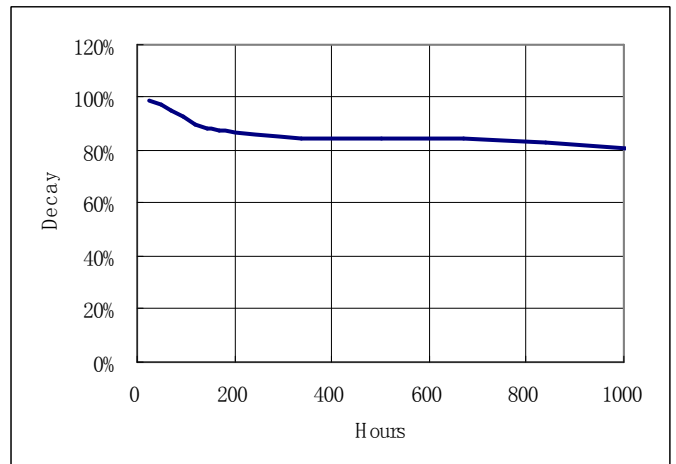

Fig4. Life Test at 20mA R.T. 1000hrs:





WCN Opto Group Co., Limited

LED Displays Reliability Test:

CLASSIFICATION	TEST ITEM	DESCRIPTION AND TEST CONDITION
ENDURANCE TEST	OPERATION LIFE	EVALUATES RESISTANCE OF THE DEVICE WHEN OPERATED AT ELECTRICAL STRESS T _a = UNDER ROOM TEMPERATURE I _F = I _F max
	HIGH TEMPERATURE HIGH HUMIDITY STORAGE	EVALUATES MOISTURE RESISTANCE OF THE DEVICE WHEN STORED FOR A LONG TERM AT HIGH TEMPERATURE AND HUMIDITY T _a = 65±5°C RH=90~95%RH TEST TIME=240± 2Hrs
	HIGH TEMPERATURE STORAGE	EVALUATES DEVICE DURABILITY FOR LONG TERM STORAGE IN HIGH TEMPERATURE T _a = 85±5°C(COB: T _a =65±5°C) TEST TIME=1000Hrs(-24Hrs, +72Hrs)
	LOW TEMPERATURE STORAGE	EVALUATES DEVICE DURABILITY FOR LONG TERM STORAGE IN LOW TEMPERATURE T _a = -35±5°C TEST TIME=1000Hrs(-24Hrs, +72Hrs)
ENVIRONMENTAL TEST	TEMPERATURE CYCLING	EVALUATES RESISTANCE OF DEVICE AT THERMAL STRESSES OR EXPANSION AND CONTRACTION 85°C ~ 25°C ~ -35°C ~ 25°C 30min 5min 30min 5min 10 CYCLES(COB: T _{hot} =65°C, T _{cold} =-25°C)
	THERMAL SHOCK	EVALUATES DEVICE STRUCTURE AND STRUCTURE AND MECHANICAL RESISTANCE WHEN SUDDENLY EXPOSED AT SERVE CHANGES 85±5°C ~ -35±5°C 10min 10min 10 CYCLES(COB: T _{hot} =65°C, T _{cold} =-25°C)
	SOLDERABILITY	EVALUATES SOLDERABILITY ON LEADS OF DEVICE T.SOL=230±5°C DWELL TIME=5±1sec.
	SOLDER RESISTANCE	EVALUATES RESISTANCE TO THERMAL STRESS CAUSED BY SOLDERING T.SOL=260±5°C DWELL TIME=10±1sec.

Packing method A:

102 pcs / Red Expandable Polyethylene.

610 pcs / Box(360*175*130mm).

3660 pcs / Carton(550*380*280mm).

Packing method B:

20 pcs / IC Tube.

840 pcs / Box(537*175*125mm).

3360 pcs / Carton(550*380*280mm).