

**WCN1-1032CB-A31****SPECIFICATION**

| WCN              |            |             | CUSTOMER<br>Confirmed |
|------------------|------------|-------------|-----------------------|
| Prepared by      | Checked by | Approved by |                       |
| Liu<br>2016-1-12 | Athena     |             |                       |
| REVISION RECORD  |            |             |                       |



REVISION: A2

■ Outer Dimension:

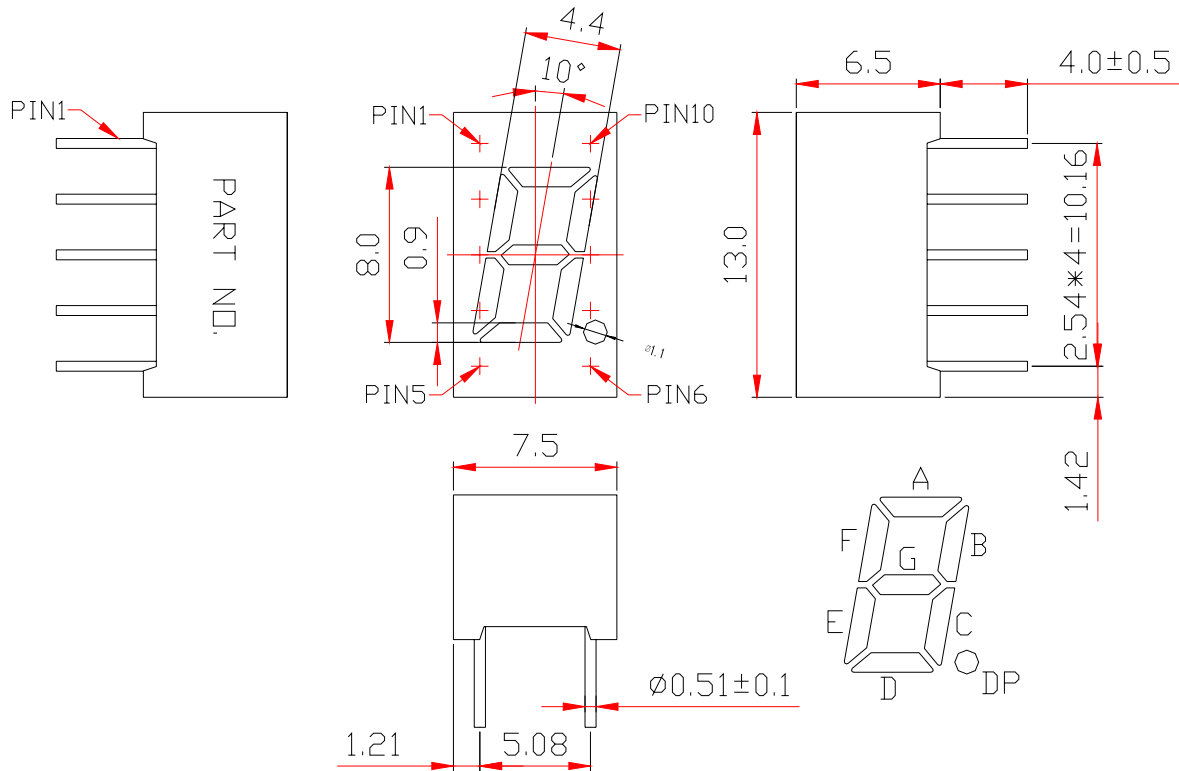

Notes: Unless otherwise stated, The tolerance is  $\pm 0.25$ mm.

■ Circuit Diagram:

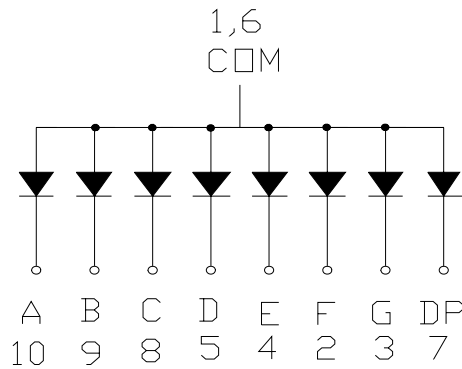

■ Pin Connection:

| PIN NO. | CONNECTION   | PIN NO. | CONNECTION   |
|---------|--------------|---------|--------------|
| 1       | Common Anode | 6       | Common Anode |
| 2       | Cathode F    | 7       | Cathode DP   |
| 3       | Cathode G    | 8       | Cathode C    |
| 4       | Cathode E    | 9       | Cathode B    |
| 5       | Cathode D    | 10      | Cathode A    |

# WCN Opto Group Co., Limited

## ■ Features:

- High Reliability
- Color: Blue
- Low Power Requirement
- Easy Assembly

## ■ Description:

- Single Digit LED Display
- Digit Height: 8.0mm(0.32" )
- Gray Face and Milky Segment

## ■ Absolute Maximum Rating (Ta=25°C):

| Parameter                        | Symbol           | Condition          | Color | Rating  | Units |
|----------------------------------|------------------|--------------------|-------|---------|-------|
| Power Dissipation Per Segment    | P <sub>d</sub>   | —                  | Blue  | 100     | mW    |
| Forward Current Per Segment      | I <sub>F</sub>   | —                  | Blue  | 25      | mA    |
| Peak Forward Current Per Segment | I <sub>FP</sub>  | 1/10 Duty<br>10KHz | Blue  | 100     | mA    |
| Reverse Voltage Per Segment      | V <sub>R</sub>   | —                  | Blue  | 5       | V     |
| Operating Temperature Range      | T <sub>opr</sub> | —                  | —     | -35~+85 | °C    |
| Storage Temperature Range        | T <sub>stg</sub> | —                  | —     | -35~+85 | °C    |

## ■ Electrical/Optical Characteristics Rating(Ta=25°C)

| Item   | Symbol           | Test conditions      | Location    | Rating |      |       | Units |
|--|------------------|----------------------|-------------|--------|------|-------|-------|
|  |                  |                      |             | Min.   | Typ. | Max.  |       |
| Forward Voltage  | V <sub>F</sub>   | I <sub>F</sub> =20mA | Per Segment | —      | 3.40 | 4.00  | V     |
| Reverse Current  | I <sub>R</sub>   | V <sub>R</sub> =5V   | Per Segment | —      | —    | 100   | μA    |
| Luminous Intensity                                     | I <sub>V</sub>   | I <sub>F</sub> =10mA | Per Segment | 2351   | 4500 | 7200  | μcd   |
| Peak Emission Wave Length                              | λ <sub>P</sub>   | I <sub>F</sub> =20mA | Per Segment | —      | 460  | —     | nm    |
|  | λ <sub>D</sub>   |                      |             | 465    | 470  | 475   |       |
| Spectral Line Half Width                               | △λ               | I <sub>F</sub> =20mA | Per Segment | —      | 20   | —     | nm    |
| Luminous Intensity Matching Ratio (Segment to Segment) | I <sub>v-m</sub> | I <sub>F</sub> =10mA | —           | —      | —    | 1.2:1 |       |

## ■ Luminous Intensity Sorting: (Luminous Intensity Tolerance is +/-10%)

| Rank | Symbol | Condition            | Min  | Max  | Unit |
|------|--------|----------------------|------|------|------|
| J    | J      | I <sub>F</sub> =10mA | 2351 | 3050 | μcd  |
| K    | K      | I <sub>F</sub> =10mA | 3051 | 4000 | μcd  |
| L    | L      | I <sub>F</sub> =10mA | 4001 | 5000 | μcd  |
| M    | M      | I <sub>F</sub> =10mA | 5001 | 6100 | μcd  |
| N    | N      | I <sub>F</sub> =10mA | 6101 | 7200 | μcd  |

■ Soldering Conditions: Soldering Temp. ≤+260°C, Soldering Time. ≤3sec.  
(at 2mm Distance from The Case of Reflector Edge)

■ **Typical Electro-Optical Characteristics Curve:**

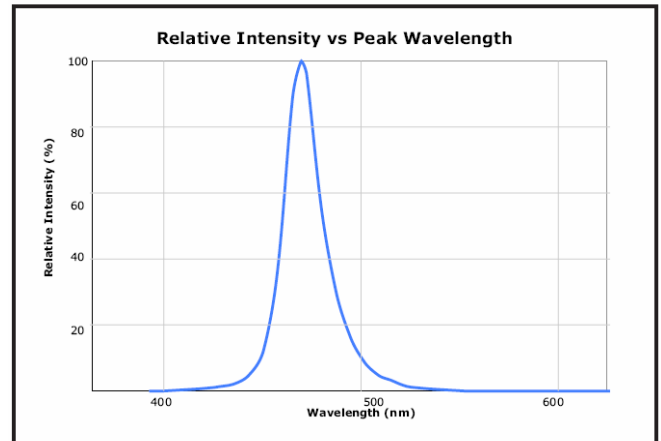
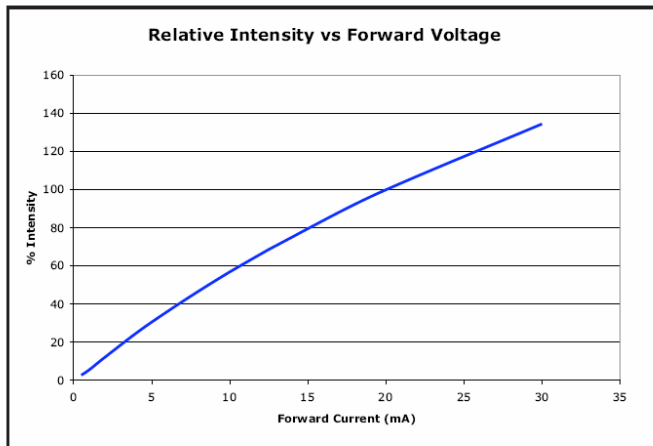
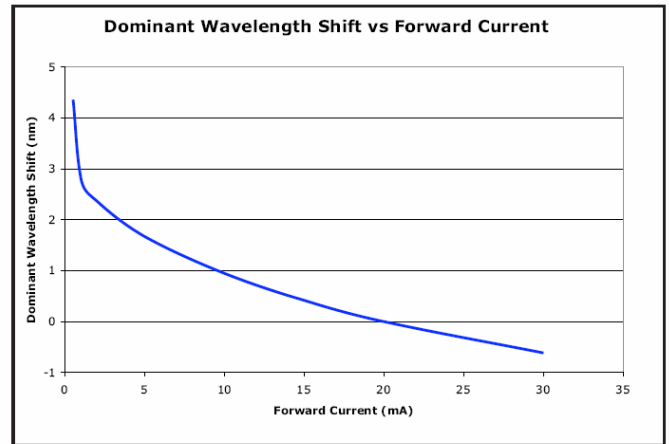
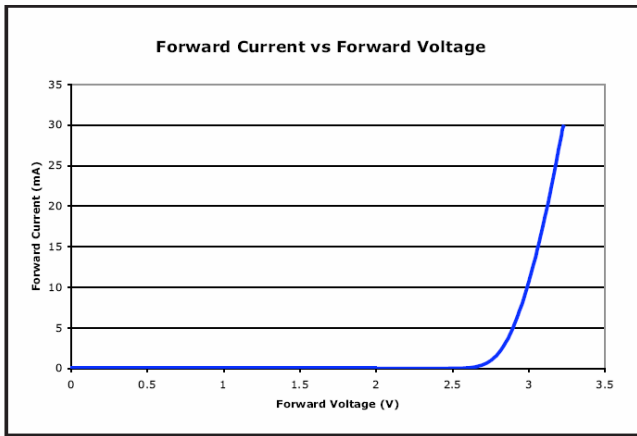

# WCN Opto Group Co., Limited

## LED Displays Reliability Test:

| CLASSIFICATION     | TEST ITEM                              | DESCRIPTION AND TEST CONDITION   |
|--------------------|--|--|
| ENDURANCE TEST     | OPERATION LIFE                         | EVALUATES RESISTANCE OF THE DEVICE WHEN OPERATED AT ELECTRICAL STRESS<br>T <sub>a</sub> = UNDER ROOM TEMPERATURE<br>I <sub>F</sub> = I <sub>F</sub> max  |
|                    | HIGH TEMPERATURE HIGH HUMIDITY STORAGE | EVALUATES MOISTURE RESISTANCE OF THE DEVICE WHEN STORED FOR A LONG TERM AT HIGH TEMPERATURE AND HUMIDITY<br>T <sub>a</sub> = 65±5°C<br>RH=90~95%RH<br>TEST TIME=240± 2Hrs  |
|                    | HIGH TEMPERATURE STORAGE               | EVALUATES DEVICE DURABILITY FOR LONG TERM STORAGE IN HIGH TEMPERATURE<br>T <sub>a</sub> = 85±5°C(COB: T <sub>a</sub> =65±5°C)<br>TEST TIME=1000Hrs(-24Hrs, +72Hrs)   |
|                    | LOW TEMPERATURE STORAGE                | EVALUATES DEVICE DURABILITY FOR LONG TERM STORAGE IN LOW TEMPERATURE<br>T <sub>a</sub> = -35±5°C<br>TEST TIME=1000Hrs(-24Hrs, +72Hrs)  |
| ENVIRONMENTAL TEST | TEMPERATURE CYCLING                    | EVALUATES RESISTANCE OF DEVICE AT THERMAL STRESSES OR EXPANSION AND CONTRACTION<br>85°C ~ 25°C ~ -35°C ~ 25°C<br>30min 5min 30min 5min<br>10 CYCLES(COB: T <sub>hot</sub> =65°C, T <sub>cold</sub> =-25°C)       |
|                    | THERMAL SHOCK                          | EVALUATES DEVICE STRUCTURE AND STRUCTURE AND MECHANICAL RESISTANCE WHEN SUDDENLY EXPOSED AT SERVE CHANGES<br>85±5°C ~ -35±5°C<br>10min 10min<br>10 CYCLES(COB: T <sub>hot</sub> =65°C, T <sub>cold</sub> =-25°C) |
|                    | SOLDERABILITY                          | EVALUATES SOLDERABILITY ON LEADS OF DEVICE<br>T.SOL=230±5°C<br>DWELL TIME=5±1sec.  |
|                    | SOLDER RESISTANCE                      | EVALUATES RESISTANCE TO THERMAL STRESS CAUSED BY SOLDERING<br>T.SOL=260±5°C<br>DWELL TIME=10±1sec.   |

## Package Pattern:

39 pcs / IC Tube.

5148 pcs / Box(360\*175\*130mm).

20592 pcs /Carton(550\*380\*280mm).