

WCNLB4-R721

SPECIFICATION

WCN			CUSTOMER Confirmed
Prepared by	Checked by	Approved by	
Fei 2016-8-5	Athena	William	
REVISION RECORD A1:New Version issued (2016-8-5)			



REVISION: A1

Outer Dimension:

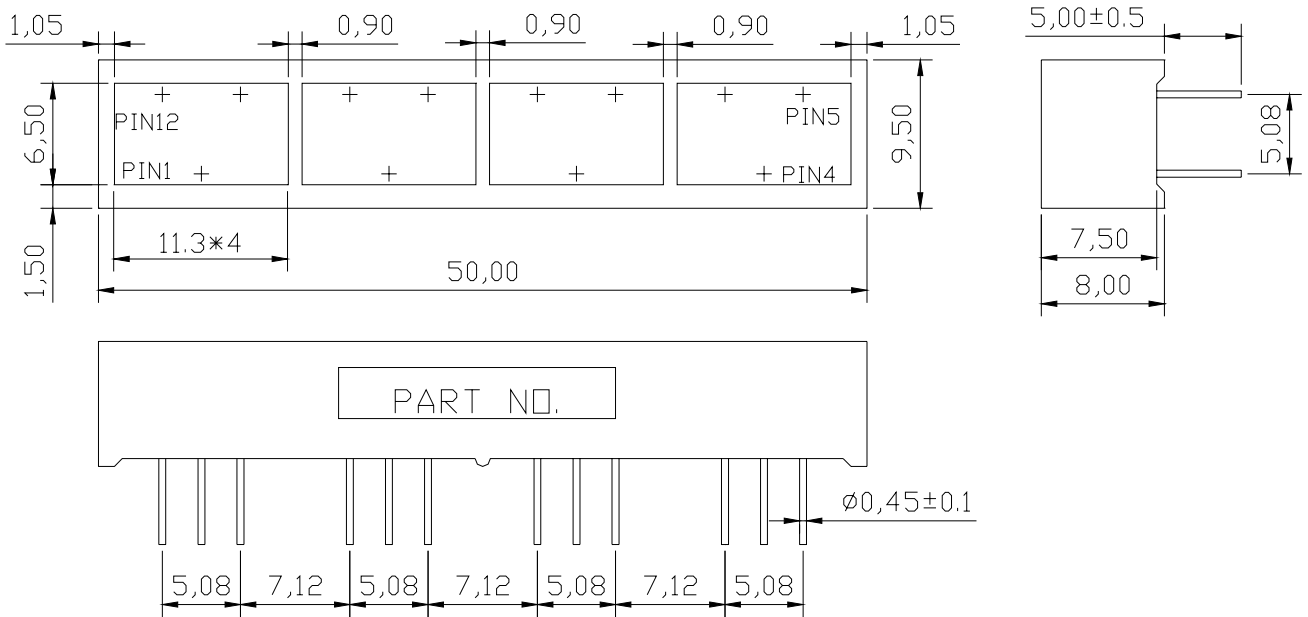

Notes: Unless otherwise stated, The tolerance is ± 0.25 mm.

Circuit Diagram:

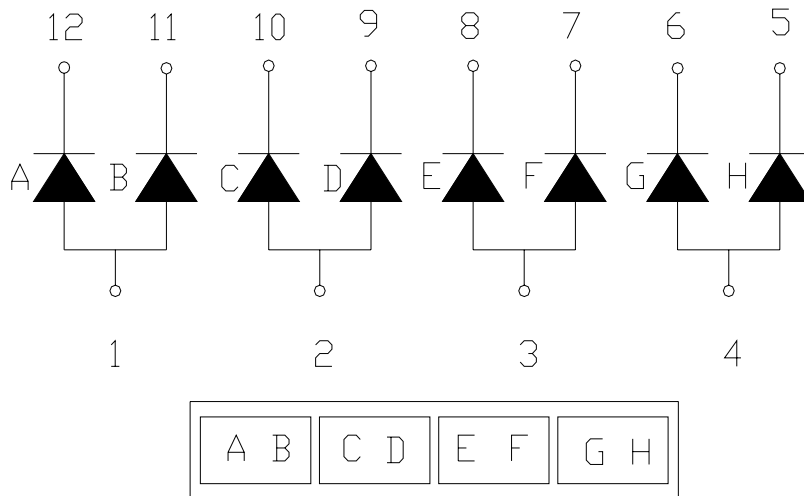

Pin Connection:

PIN NO.	CONNECTION	PIN NO.	CONNECTION	PIN NO.	CONNECTION
1	Anode A,B	5	Cathode H	9	Cathode D
2	Anode C,D	6	Cathode G	10	Cathode C
3	Anode E,F	7	Cathode F	11	Cathode B
4	Anode G,H	8	Cathode E	12	Cathode A

■ **Features:**

- High Reliability
- Color: Super Bright Red.
- Low Power Requirement
- Easy Assembly

■ **Description:**

- Four Windows Display
- Digit Height 6.5mm(0.26") and Width 11.3mm(0.44")
- White Face and Red Bar

■ **Absolute Maximum Rating (Ta=25°C):**

Parameter	Symbol	Condition	Color	Rating	Units
Power Dissipation Per Bar	P _d	—	Red	65	mW
Forward Current Per Bar	I _F	—	Red	25	mA
Peak Forward Current Per Bar	I _{FP}	1/10 Duty 10KHz	Red	100	mA
Reverse Voltage Per Bar	V _R	—	Red	5	V
Operating Temperature Range	Topr	—	—	-35~+85	°C
Storage Temperature Range	Tstg	—	—	-35~+85	°C

■ **Electrical/Optical Characteristics Rating(Ta=25°C)**

Item	Symbol	Test conditions	Location	Rating			Units
				Min.	Typ.	Max.	
Forward Voltage	V _F	I _F =20mA	Per Bar	—	2.0	2.60	V
Reverse Current	I _R	V _R =5V	Per Bar	—	—	100	μA
Luminous Intensity	I _V	I _F =10mA	Per Bar	5051	10500	20000	μcd
Wave Length	λ _P	I _F =20mA	Per Bar	—	630	—	nm
	λ _D				622		
Spectral Line Half Width	△λ	I _F =20mA	Per Bar	—	30	—	nm
Luminous Intensity Matching Ratio (Bar to Bar)	I _{v-m}	I _F =10mA				1.2:1	

■ **Luminous Intensity Sorting: (Luminous Intensity Tolerance is +/-10%)**

Rank	Symbol	Condition	Min	Max	Unit
K	K	I _F =10mA	5051	8000	μcd
L	L	I _F =10mA	8001	12560	μcd
M	M	I _F =10mA	12561	20000	μcd

■ **Soldering Conditions: Soldering Temp. ≤ +260°C Soldering Time. ≤ 3sec.**
 (at 2mm Distance from The Case of Reflector Edge).

■ Typical Elector-Optical Characteristics Curve:

Fig 1. Forward Current vs. Forward Voltage

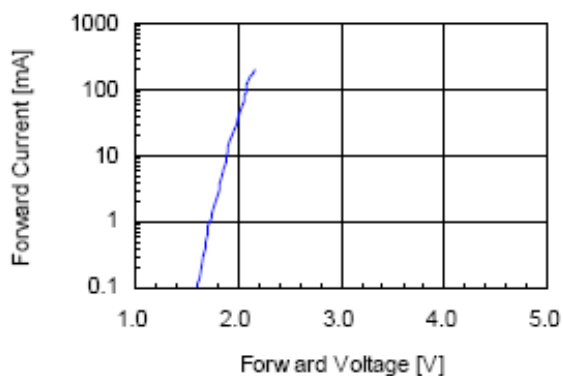

Fig 2. Relative Intensity vs. Forward Current

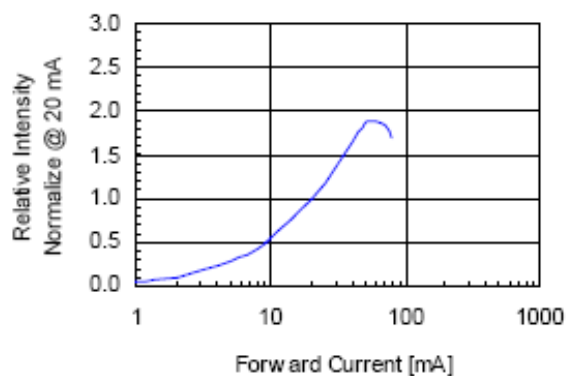

Fig 3. Forward Voltage vs. Temperature

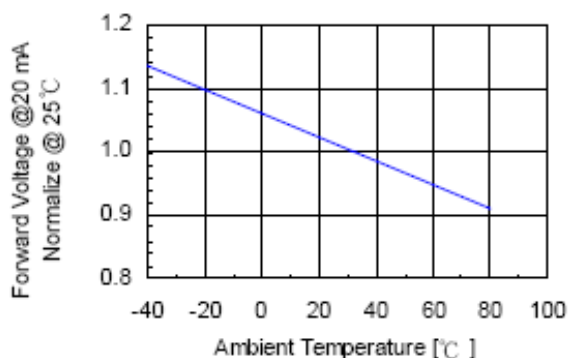

Fig 4. Relative Intensity vs. Temperature

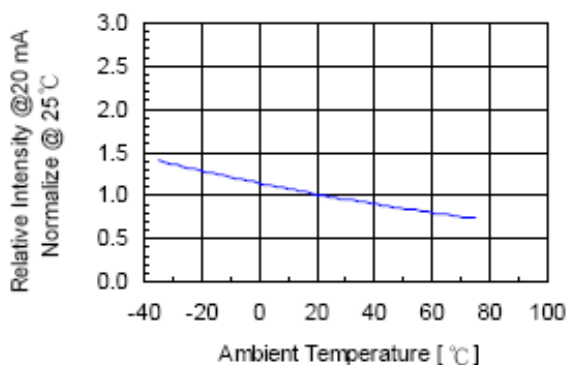
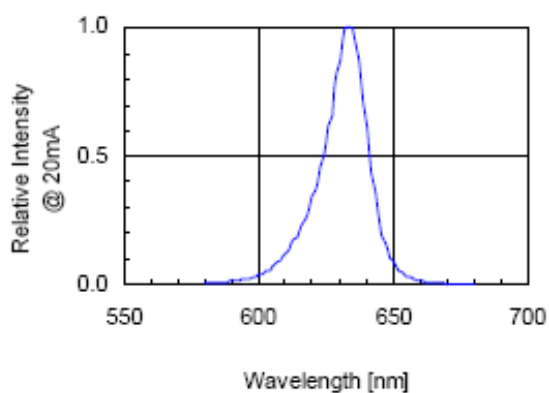

Fig 5. Relative Intensity vs. Wavelength



LED Displays Reliability Test:

CLASSIFICATION	TEST ITEM	DESCRIPTION AND TEST CONDITION
ENDURANCE TEST	OPERATION LIFE	EVALUATES RESISTANCE OF THE DEVICE WHEN OPERATED AT ELECTRICAL STRESS T _a = UNDER ROOM TEMPERATURE I _F = I _F max
	HIGH TEMPERATURE HIGH HUMIDITY STORAGE	EVALUATES MOISTURE RESISTANCE OF THE DEVICE WHEN STORED FOR A LONG TERM AT HIGH TEMPERATURE AND HUMIDITY T _a = 65±5°C RH=90~95%RH TEST TIME=240± 2Hrs
	HIGH TEMPERATURE STORAGE	EVALUATES DEVICE DURABILITY FOR LONG TERM STORAGE IN HIGH TEMPERATURE T _a = 85±5°C (COB: T _a =65±5°C) TEST TIME=1000Hrs(-24Hrs, +72Hrs)
	LOW TEMPERATURE STORAGE	EVALUATES DEVICE DURABILITY FOR LONG TERM STORAGE IN LOW TEMPERATURE T _a = -35±5°C TEST TIME=1000Hrs(-24Hrs, +72Hrs)
ENVIRONMENTAL TEST	TEMPERATURE CYCLING	EVALUATES RESISTANCE OF DEVICE AT THERMAL STRESSES OR EXPANSION AND CONTRACTION 85°C ~ 25°C ~ -35°C ~ 25°C 30min 5min 30min 5min 10 CYCLES(COB: T _{hot} =65°C, T _{cold} =-25°C)
	THERMAL SHOCK	EVALUATES DEVICE STRUCTURE AND STRUCTURE AND MECHANICAL RESISTANCE WHEN SUDDENLY EXPOSED AT SERVE CHANGES 85±5°C ~ -35±5°C 10min 10min 10 CYCLES(COB: T _{hot} =65°C, T _{cold} =-25°C)
	SOLDERABILITY	EVALUATES SOLDERABILITY ON LEADS OF DEVICE T.SOL=230±5°C DWELL TIME=5±1sec.
	SOLDER RESISTANCE	EVALUATES RESISTANCE TO THERMAL STRESS CAUSED BY SOLDERING T.SOL=260±5°C DWELL TIME=10±1sec.

Packing method :

102pcs / Red Expandable Polyethylene.

610 pcs / Box(360*175*130mm).

3660 pcs / Catton(550*380*280mm).